



MRA600



- ▶ 5-Axis high speed machining center designed for precision mold, precision parts, complex hardware processing, positioning processing and 5-axis simultaneous processing of heavy workpiece.



JINGDIAO 5-AXIS HIGH-SPEED MACHINING CENTER

MRA600



Learn More
About MRA600



Highlights

- 01 Heavy load rotary table (max 881.84lb) with good stability, and the a-axis uses double-drive technology.
- 02 The machines are capable of milling, grinding, drilling, boring, tapping and other composite processing.
- 03 63 capacity tool magazine capacity, meeting the needs of complex mold processing.
- 04 Workpiece position on-machine measuring and size deviation intelligent modifying, dimensional accuracy is improved.



Max. load (kg/lb):
400/881.84



01 02
03 04



Machining Samples

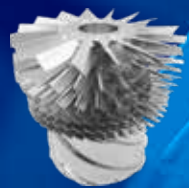

Turbo Molecular Pump 7-Level Impeller

- Size (mm/in):** $\phi 350 \times 286 / \phi 13.78 \times 11.26$
- Material:** Aluminum Alloy (7075-T6)
- Highlights:**
- + The virtual processing technology ensures the 5-axis processing safety;
 - + Roughing and finishing of 249 blades can be completed with one clamping for 16h;
 - + Unbalance is less than 0.6 gmm.

Flywheel Housing Die Casting

- Size (mm/in):** $578 \times 560 \times 178 / 22.76 \times 22.05 \times 7.01$
- Material:** ADC12 (HB90) 12% Silicon
- Highlights:**
- + The workpiece can be clamped at one time to complete multi-position processing;
 - + Using 51 tools;
 - + Milling, boring, drilling, tapping, reaming and other processing methods are used.

Gear Cover Die Casting

- Size (mm/in):** $470 \times 335 \times 40 / 18.50 \times 13.19 \times 1.57$
- Material:** ADC12 (HB90) 12% Silicon
- Highlights:**
- + JINGDIAO on-machine measurement technology intelligently compensates workpiece position;
 - + Remaining stock of surface is at least 0.2 mm after CNC machining, the distance error from the reference surface is less than 0.1 mm.

Machine Structure

Max. Workpiece Dimension Unit: mm (in)

Max. load (kg/lb): 400/881.84

Travel (X/Y/Z) mm/ (in)	650/660/500 (25.60/25.98/19.69)
A/C Rotation Angle (deg)	-120~90/360

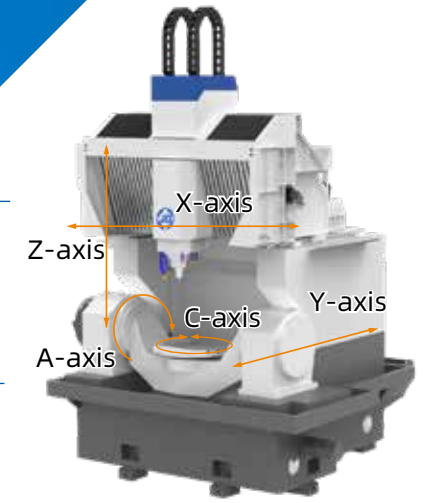
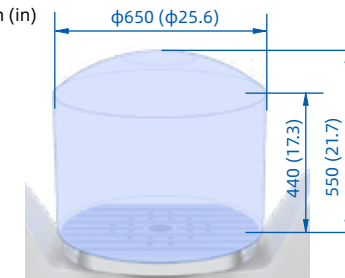

Optimum Structural Design

- + Moving beam gantry structure design.
- + Symmetrical design and the motion axis distribution is reasonable.



Good Thermal Stability

- + All round cooling design, using rotary table cooling, bearing cooling, screw cooling technology.



Linear Glass Scales

- + Equipped with linear scale to compensate the transmission error and the lead screw elongation caused by temperature change.

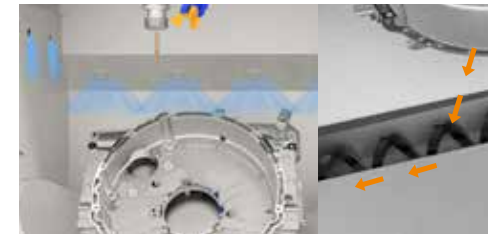

Convenient for Chip Cleaning

- + Internal spray device, 23° gradient machine bed and spiral chip conveyor, more convenient for chip disposal. (Match with the scraper type chip conveyor system (page 9) outside the machine, ensures a good chip removal effect).

Ergonomics

Ergonomic factors is taken into account in the design of structure layout, chip removal device and human-machine coordination of machine, effectively improve the use comfort and convenience.

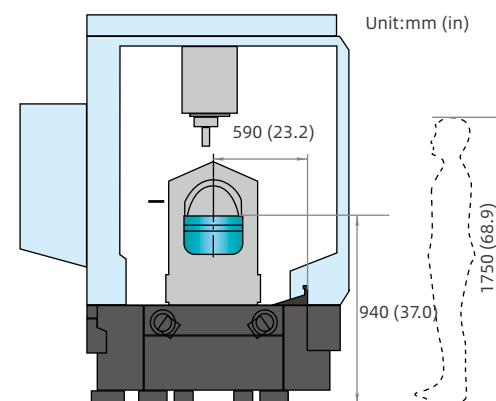

- + Relevant parts designing such as the console, worktable and viewing window based on the operator's anthropometric data, improve comfort level and reduce fatigue.
- + Multiple-door design makes it easy for operator to use and maintain the machine.
- + The front door has a large opening size and the top is equipped with automatic door, convenient loading and unloading.
- + The chip conveyor is completed by the in-machine spiral chip conveyor rod, reduce the workload of manual chip cleaning.

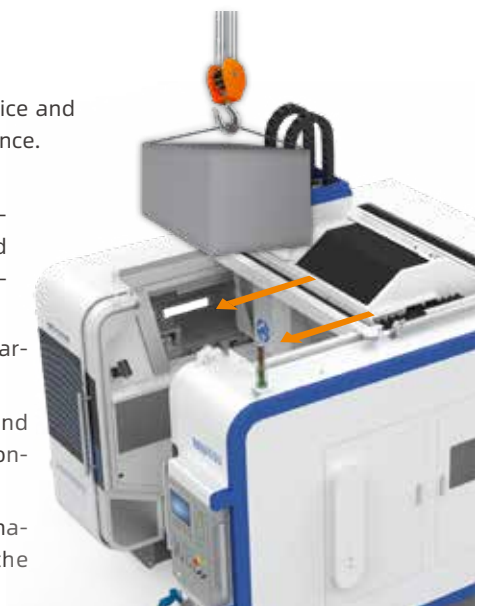

Key Components

JINGDIAO High-Speed Precision Spindle

— Strong Cutting Ability

Various types of spindle can meet the MRA600 machine for heavy workpiece, large amount of chip cutting, deep cavity and other conditions processing. Can not only process cornering processing with small cutting tools, but also realize the boring processing with large cutting tools.

4 types high-speed precision spindles with large torque can be chosen, such as JD150S-20-HA50/C, JD150SC-20-HA50/A, JD180SC-15-HA63/B, JD180S-15-HA63/B. Among them, JD150S-20-HA50/C is the standard spindle, others are optional spindles, JD150SC-20-HA50/A and JD180SC-15-HA63/B are coolant through spindles.

- Deep Hole Machining



High Speed & Low Vibration



JD180SC-15-HA63/B (Coolant Through Spindle)

Optionally 5Mpa (725.18Psi) 180mm ($\phi 7.08$ in) coolant through spindle and internal cooling tool, realizing deep hole and deep cavity machining, good cutting cooling effect.

Output Performance

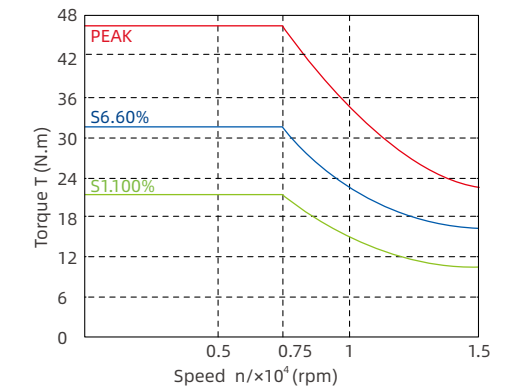
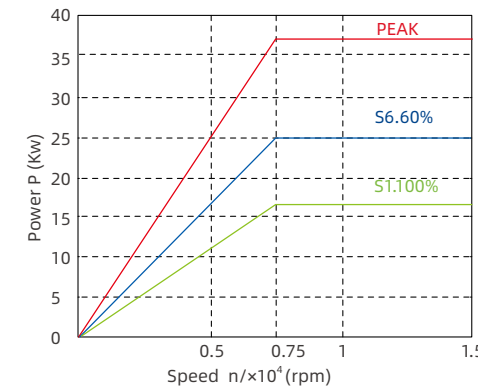

Basic Specification

Clamping Diameter (mm/in): $\phi 180/\phi 7.1$ (0, -0.009)
 Output Power (56-60%) (Kw): 25
 Output Torque (56-60%) (Nm): 32
 Speed (rpm): 15,000
 Tool Holder: HSK-A63
 Weight (kg/lb): 71/156.5

Performance

- + Taper bore radial runout $\leq 1.5 \mu\text{m}$ (5.9×10^{-5} in)
- + Rotor end face axial runout $\leq 1 \mu\text{m}$ (3.9×10^{-5} in)
- + Vibration at maximum speed $\leq 0.6 \text{ mm/s}$ (1.44 ipm)

Available Tools (Part)

Variety of tools like disc tool, boring tool, drill, screw tap, gang feed reamer, internal cold corn milling tool, internal cooling drill etc. can be used, meeting the complex mold composite processing need.



Dimension

Unit:mm (in)

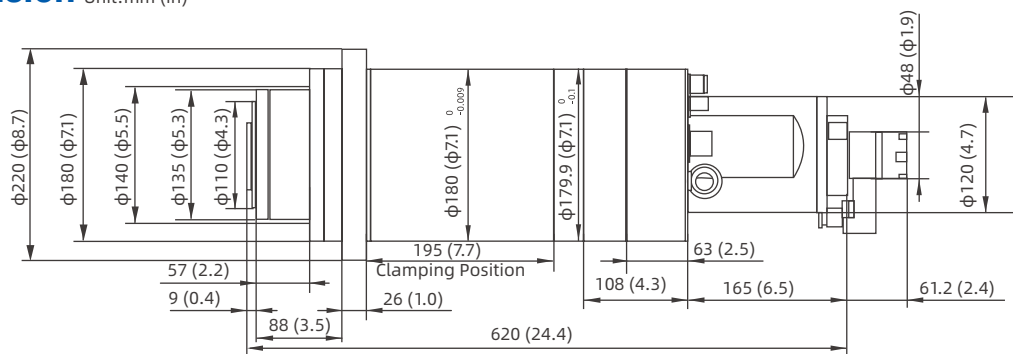

Features

- + The coolant can be ejected from the tool's front end and applied directly to the cutting position.
- + Used for drilling, tapping, reaming, corn side milling, etc.
- + High pressure coolant liquid can directly take out the chip, avoiding tool winding and breaking.
- + MCP machine tool operation panel.
- + High cutting efficiency, good cooling performance.

Standard

JD150S-20-HA50/C
 Speed (rpm): 20,000
 Tool Holder: HSK-A50



Optional

JD180S-15-HA63/B
 Speed (rpm): 15,000
 Tool Holder: HSK-A63

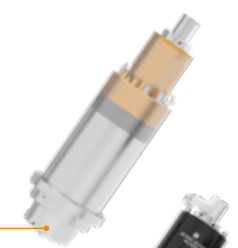

JD150SC-20-HA50 /A(Coolant Through Spindle)

Speed (rpm): 20,000
 Tool Holder: HSK-A50



JD50 CNC System

The JD50 CNC system is developed independently by Beijing JINGDIAO. The control is highly efficient, reliable and very precise. Additionally, it has Rich Programming Functions, Convenient Operation, Flexible Peripheral Control, and Can Meet the processing requirements of high machining accuracy and fine surface finishing.



Configurations

- + The programming resolution and control resolution are 0.1 μm (3.9×10⁻⁶ in).
- + Supports linear, plane arc, space arc, spiral line, spline and involute interpolation methods.
- + Support pitch compensation and reverse clearance compensation.
- + Support RTCP multi-axis motion control.



0.1μm Feed, 1μm Cutting

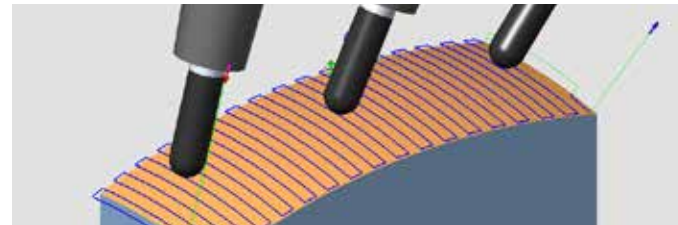

Fixed Point Cutting

Not RTCP Program

```
G91G28Z0
G90
G0X0.7883Y2.4874A-90.C-77.1431
M590 L1
G43H1
Z35.0874
Z30.6074
N102G1Z30.1074F189.
```

Not intuitive

RTCP Program

```
G91G28Z0
G90
G68.2X29.3331Y6.6949Z-6.1-77.143]-90.K0.
G53.1
G0X0.7883Y-3.5126
M590 L1
G43H1
Z5.
Z0.52
N102G1Z0.02F189.
```

Intuitive

RTCP

Five-Axis Programming Features

- + Tool center point control function.
- + Inclined plane machining function.
- + Cylinder interpolation function.
- + Polar coordinate interpolation function.

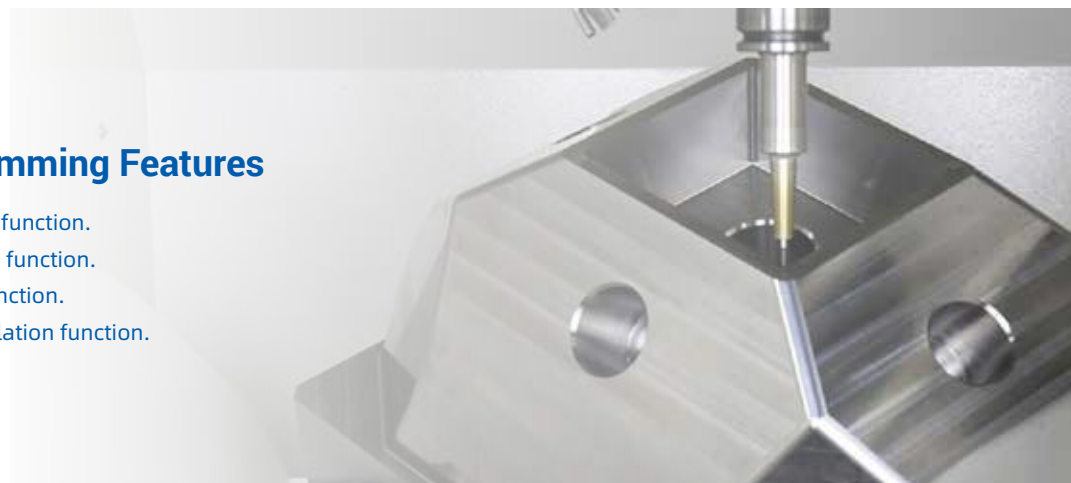

System Advantages

- + Various programming methods and flexible technical process design.
- + Abundant types of interfaces and buses, and strong peripheral expansion capabilities.
- + Unique external extended function instructions (G100), which can realize instruction-level peripheral control, human-computer interaction, and complex data operations.

Advanced Features

- + Includes on-machine contact and non-contact measurement functions, which results in high-precision 2D and 3D measurements.
- + Built-In CAM technology and intelligent modification technology supports the on-machine tool-path deformation compensation machining.
- + Incorporates multiple communication protocols and remote monitoring.

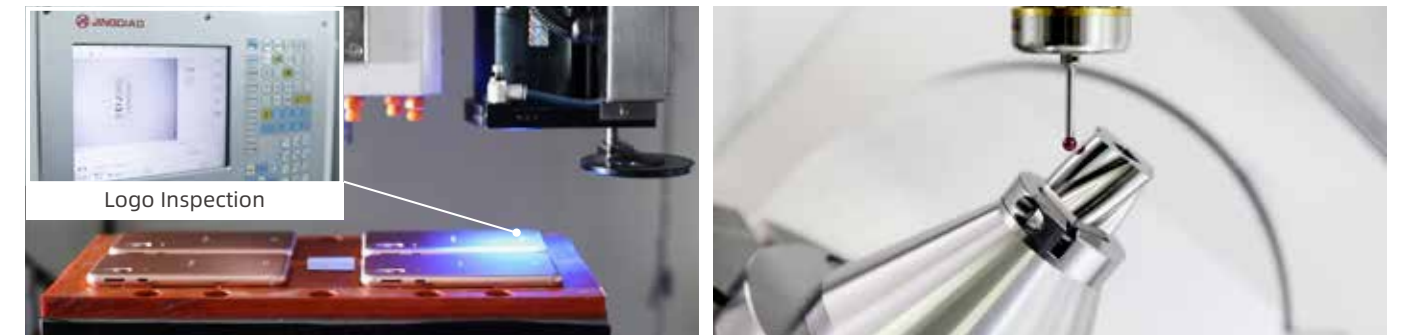

Non-Contact Measurement

Contact Measurement

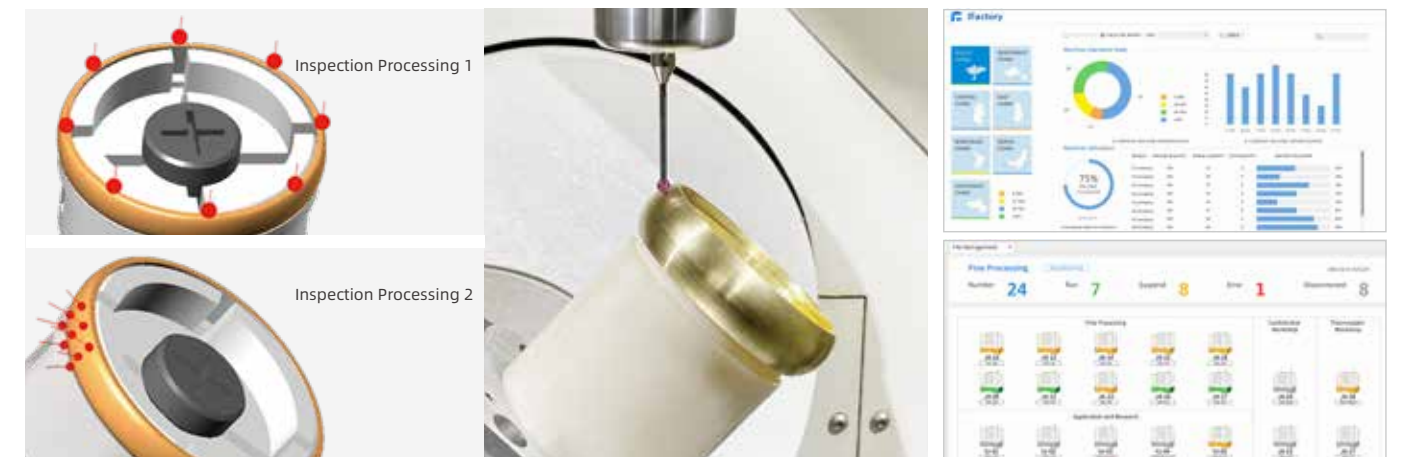

Surface Deformation Compensation

Remote Monitoring of Machines



Tool Magazine

Maximum 63 tool magazine capacity, meeting the needs of complex mold processing, and a variety of tool magazine for you to choose, to meet different production needs.



Type	Chain Type Tool Magazine with Manipulator
Capacity	63
Tool Holder	HA50
Allowable Maximum Tool Length (mm/in) (From End of Spindle)	270/10.6
Maximum Diameter of Contiguous Tools (Full) (mm/in)	50/2.0
Maximum Diameter of Contiguous Tools (Vacant) (mm/in)	140/5.5
Max. Load of Each Position (kg/lb)	4/8.8
Max. Load of Tool Magazine (kg/lb)	120/264.6

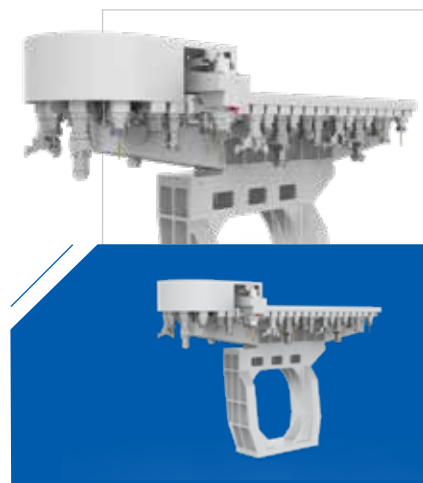

Type	Chain Type Tool Magazine with Manipulator
Capacity	51
Tool Holder	HA63
Allowable Maximum Tool Length (mm/in) (From End of Spindle)	270/10.6
Maximum Diameter of Contiguous Tools (Full) (mm/in)	65/2.6
Maximum Diameter of Contiguous Tools (Vacant) (mm/in)	140/5.5
Max. Load of Each Position (kg/lb)	6/13.2
Max. Load of Tool Magazine (kg/lb)	120/264.6

Cradle Type Double Direct Drive Rotary Table

- + Heavy Load (kg/lb): Max 400 (881.84)
- + Large Diameter mm (in): Max $\phi 630$ ($\phi 24.8$)
- + Good Rigidity, High Stability

Dimension Unit:mm (in)

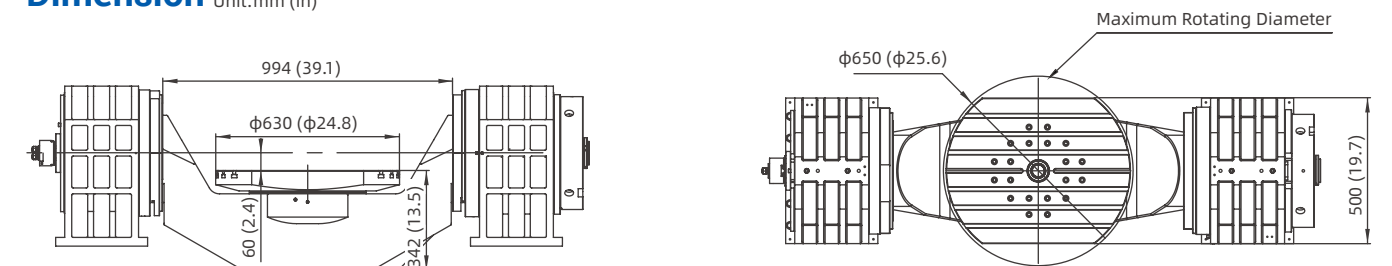

Features

- + A-axis symmetrical double motor structure, uniform output, small deformation.
- + The a and c axis of rotary table is equipped with brake mechanism, ensure the rigidity of the rotary table.
- + Bridge deck tailstock structure, high precision and stable operation.
- + Circulating water cooling reduces the thermal deformation.
- + Optionally equipped with revolving joint for easy fixture arrangement.

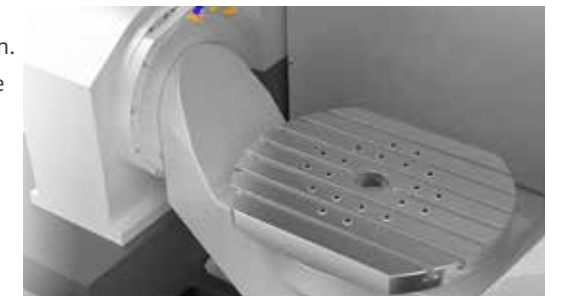

Specification

Item	Tilt Axis	Rotation Axis
Drive Mode	Direct Motor Drive	Direct Motor Drive
Table Diameter (mm/in)	--	$\phi 630/\phi 24.80$
Maximum Load (kg/lb)	--	400/881.84
Position Accuracy (")	8	8
Repeatability (")	5	5
Rapid Feed Rate (rpm)	60	60
Rotation Angle (°)	210 (-120~90)	360 (Continuous)
Cooling Mode	Circulating Water Cooling	Circulating Water Cooling
Positioning Locking Mode	Hydraulic Locking	Hydraulic Locking
Positioning Locking Air Pressure (Mpa/Psi)	0.35~0.4/50.76~58.02	0.35~0.4/50.76~58.02
Brake Mode	Pneumatic Locking	--

Accessories

Scraper Type Chip Conveyor System — Suitable for Large Amount of Chip Cutting Processing

It can be used to separate and collect waste liquid and chip effectively, prolong the cycle of waste chip cleaning, and avoid the blocking of chip outlet of machine tool to affect the continuity of machining.

Features

- + Improves maintenance by moving the chips into disposal container.
- + Cutting fluid service life is extended by using a multistage filtration unit.
- + Equipped with a cleaning mechanism and drop recovery mechanism which is self cleaning resulting cutting fluid recovery.

Chip Conveyor Principle

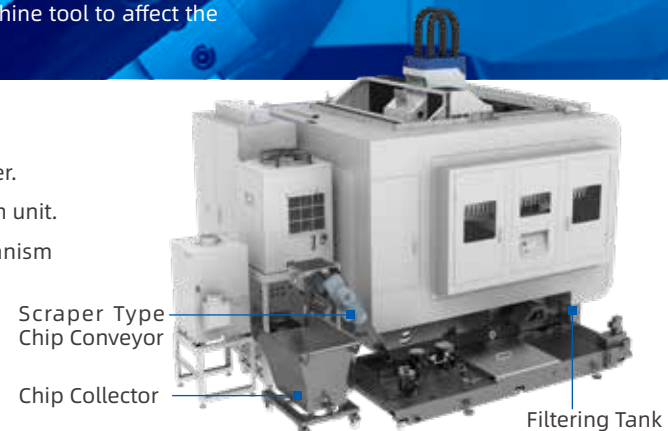
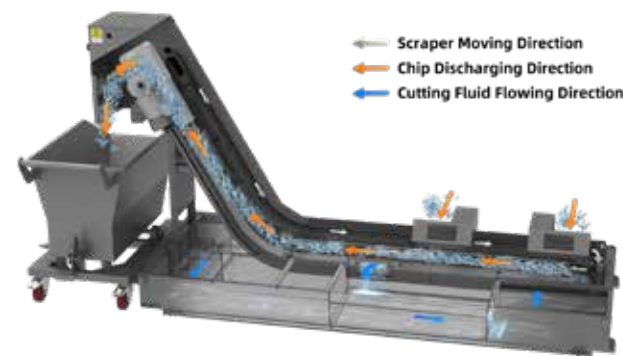

Appropriate Chip Types

Material	Chip Form	Chip Size	Applicability
Steel		Long	●
		Short	●
		Powder	●
Cast Iron		Short	●
		Powder	●
Aluminum/ Non-ferrous Metal		Long	●
		Cumulus	●
		Short	●

● :Ideal ● :Suitable ● :Not Suitable

Cutting Fluid Tank

The cutting fluid circulation system plays the role of cooling, lubrication, cleaning and chip removal, which can improve product quality, reduce tool wear.

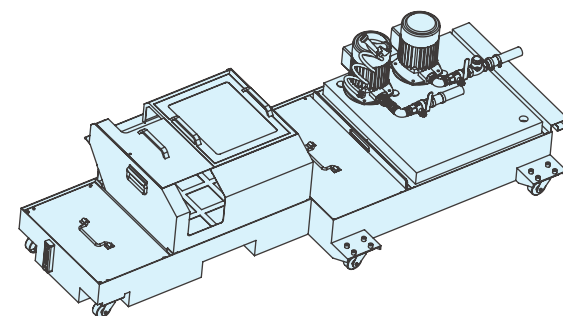

Minimal Quantity Lubrication (MQL)

Equipped with MQL, the temperature fluctuation in the machine can be controlled within 0.5 °C (32.9 °F).



Specification

Item	Spec
Pressure (Mpa/Psi)	0.5~0.8/73.5~117.6
Working Pressure (Mpa/Psi)	0.55/80.8
Air Volume (L/min)	0~220
Air Consumption per Nozzle (L/min)	100
Oil Consumption per Nozzle (mL/h)	0~30
Nozzle Quantity	2
Weight (kg/lb)	1.5/3.3
Mounting Pitch (mm/in)	70/2.8

Dimension Unit: mm (in)

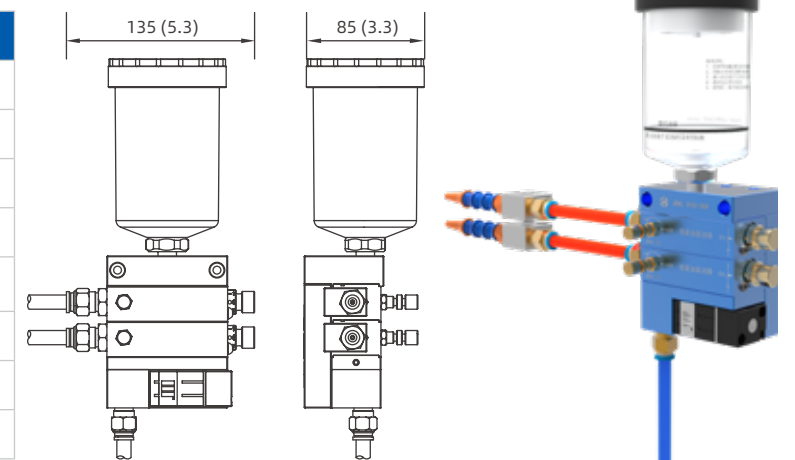

Oil Mist Collector

The oil mist collector reduces the rise of internal temperature caused by the oil mist accumulation. It eliminates the diffusion of oil mist, reduces the internal electrical fault of the machine tool, improves the stability of equipment operation, reduces air pollution, and protects the workshop environment.



Specification

Item	Spec
Voltage (V)	AC380±10%
Power (W)	800
Current (A)	1.5
Frequency (Hz)	50±2%
Ambient Temperature (°C / °F)	5~40/41~104
Environmental Pressure	Atmos
Weight (kg/bl)	80/176.4
Max. Air Volume (m ³ /in ³)	800/4.9×10 ⁷
Filtration Efficiency	> 99%

JDACM800 Oil mist collector ▶

Spindle & Rotary Table Refrigerator

Good Refrigeration Effect :

- + It is used for cooling of spindle, electric control cabinet and screw.
- + With constant temperature, follow and automatic three control modes.

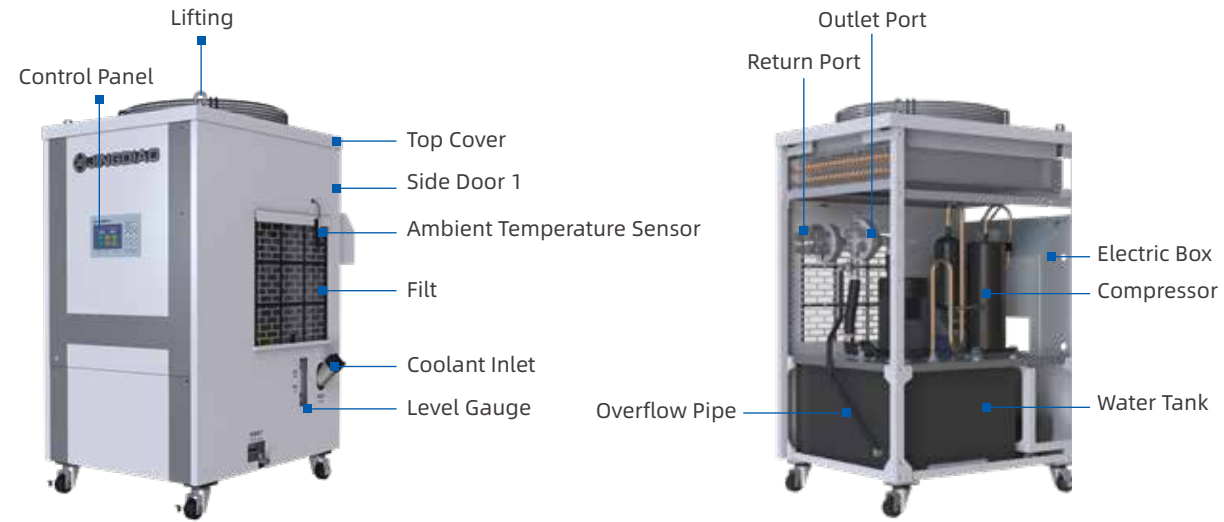

Specification

Type	Specification
Input Voltage	AC three phase 380v±10% 50Hz
Apparent Power (KVA)	3.6
Rated Cooling Capacity (Kw)	5 (Environment temperature is 25°C / 77 °F , compressor frequency is 50Hz)
Coolant Temperature Range (°C / °F)	5~40/41~104
Coolant Temperature Control Accuracy (°C / °F)	±0.1/31.82~32.18
Working Environment Temperature Range (°C / °F)	0~45/32~113
Compressor	20Hz~60Hz Frequency
Refrigerant	R410A
Refrigerant Charge (kg/lb)	1.32/2.871
Max Working Pressure (Mpa/Psi)	4.0/580.2
Water Tank Capacity (L/gal)	48/12.7
Coolant	Pure water & DOWTHERM
Water Pump Power (Kw)	0.80
Water Flow (L/min) / (gal/min)	≥2.0/0.53 (Related to the spindle and rotary table); ≥1.0/0.26 (Related to the screw)
Pump Max Lift (m/in)	52/2047.2
Noise (dB)	≤64
Net Weight (kg/lb)	140
Dimension (mm/in)	550×825×1075 (21.65×32.48×42.32)

Tool Holders

Tool holders require good clamping performance such as high clamping accuracy, low vibration and the ability minimize oil mist during high-speed machining.

JINGDIAO tool holders have anticorrosive properties, minimize Air Resistance , and are designed good dynamic balance. And a variety of types are available to adapt to a variety of processing scenarios by using MRA600.

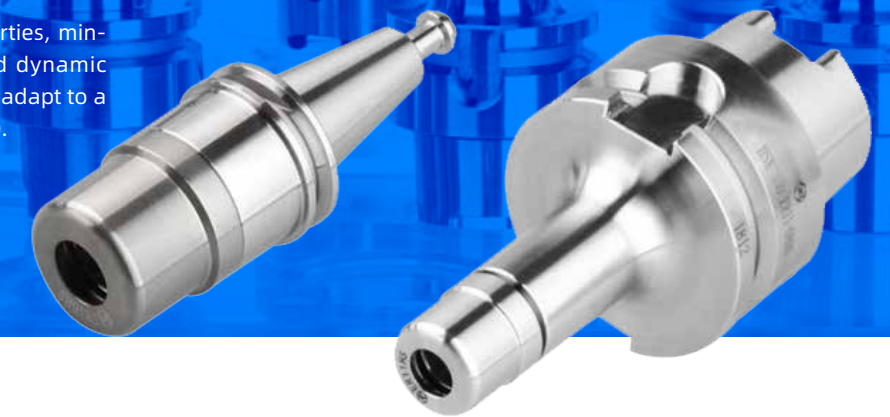

Dimension Chart

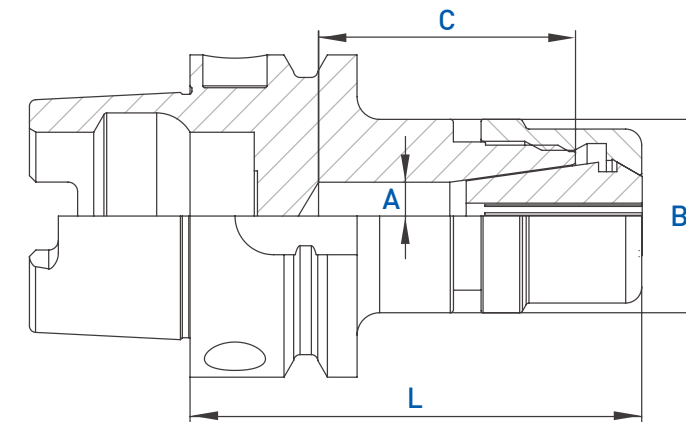

Technical Parameter

Type	Name	Size mm (in)				
		A	B	C	L	Thread
HSK-A	HSK-A50-ER11-080S	7 (0.28)	19 (0.75)	30 (1.18)	80 (3.15)	M14×0.75
	HSK-A50-ER16-070S	10.5 (0.41)	30 (1.18)	40 (1.57)	71 (2.95)	M22×1.5
	HSK-A50-ER16-110S	10.5 (0.41)	30 (1.18)	40 (1.57)	111 (4.37)	M22×1.5
	HSK-A63-ER32-080S	23.5 (0.93)	60 (2.36)	39 (1.54)	80 (3.15)	M40×1.5

Distinctive Technologies

On-Machine Measurement and Intelligent Modification Technology

JINGDIAO's innovative On-Machine Measurement and Intelligent Modification Technology (OMIM) is an Ideal solution that integrates CAD/CAM programming technology, numerical control processing and precision inspection technology. It's intelligent application can effectively shorten the production cycle of the workpiece, streamline the processing flow, and improve quality and efficiency for production and machining.

The Function of JINGDIAO OMIM is Mainly Reflected in Three Aspects

+ Intelligent Workpiece Alignment

This feature automatically corrects the workpiece deviation through inspecting the offset of workpiece on machine and adjusting the program in control system. This reduces workpiece setup time, improves machining quality and increases production.

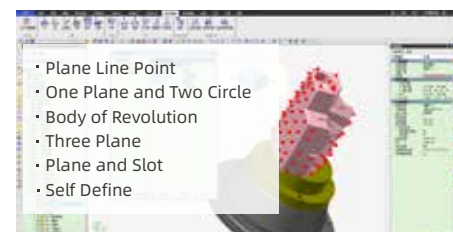

01-Support Multiple Workpiece Position Compensation Methods



02-Obtain Actual Position on the Machine

ID-6	Remain 0.10883	ID-7	Remain 0.10347
ID-5	Remain 0.10985	ID-8	Remain 0.10245
ID-4	Remain 0.10868	ID-9	Remain 0.10325
ID-3	Remain 0.10828	ID-10	Remain 0.10229
ID-2	Remain 0.10860	ID-11	Remain 0.10302
ID-1	Remain 0.10789		

Before Modification: 7 μm

ID-6	Remain 0.10234	ID-7	Remain 0.10219
ID-5	Remain 0.10287	ID-8	Remain 0.10136
ID-4	Remain 0.10169	ID-9	Remain 0.10187
ID-3	Remain 0.10130	ID-10	Remain 0.10101
ID-2	Remain 0.10161	ID-11	Remain 0.10174
ID-1	Remain 0.10289		

After Modification: 4 μm

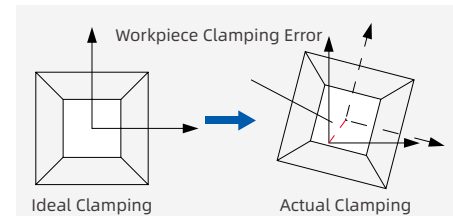

03-Workpiece Position Compensation



04-Verification of Position Compensation Accuracy

+ Intelligent Workpiece Alignment

With this feature, the remaining stock at each machining step can be measured in real time, and the inspection results will be displayed on the machine's control. The operator can analyze the results in order to ensure that an even amount of material is removed at every machining step. This results in reduced tool wear, constant chip load, improved machining accuracy and improved surface finishes.



Inspect the Remaining Stock on the Machine

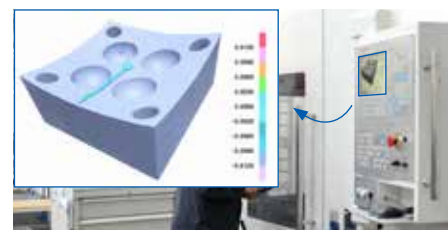

Real Time Display of CNC System



Achieve Stable Precision Machining

+ 5-Axis Path On-Machine Compensation

The CAM function embedded in the CNC system can compensate for the inaccurate machining path, which is created by a non-conforming geometric shapes, clamping deformation and clamping deviation.

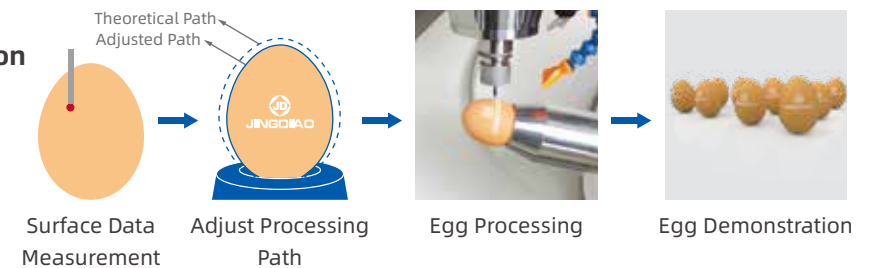

A New Model of Numerical Control Processing

- + Machining and inspection are achieved one machine, forming a new model of "integration of machining and inspection".
- + The digitalization of CNC machining experience enables a entry-level operator to complete precision machining.
- + The actual processing time proportion of CNC machines has increased from **25% -45% to 45% -70%**.



Before Using Integration of Machining and Inspection



After Using Integration of Machining and Inspection

Tool Inspection System

During the 5-axis machining process, JINGDIAO tool inspection system can inspect the errors of different positions of the Tool contour of the bull nose tool, ball-end tool and other tools for precision machining and compensate intelligently. This can effectively reduce the unqualified workpiece accuracy caused by the tool inaccuracy.



* Tool Type

Realization

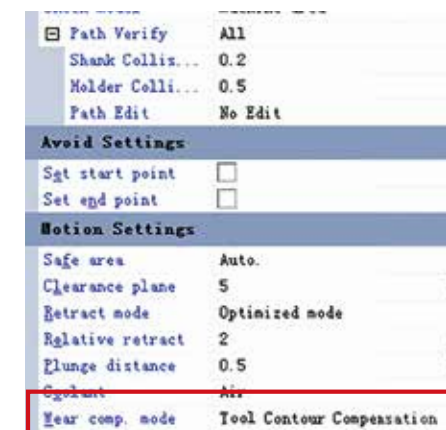
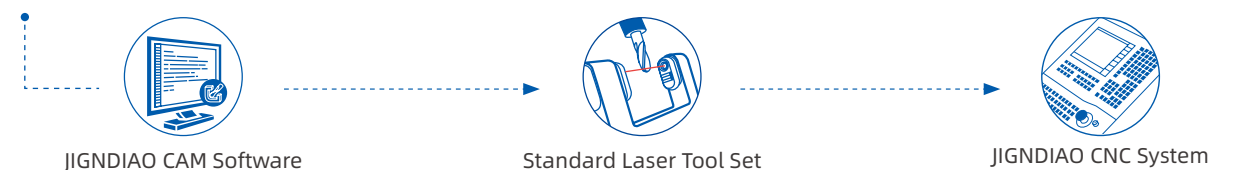

3D Tool Contour Compensation Function



Inspect Tool Contour on the Machine

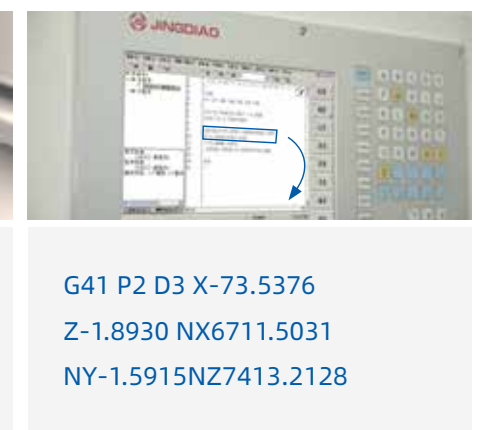

Compensate Tool Contour Deviation

JINGDIAO Digital Twin (DT) Technology

With Jingdiao's software, the actual production materials and process parameters are digitized to ensure the correct information is selected by the process personnel, material preparation personnel and the operator. This creates a seamless integration process development, material preparation and machine operation, and improves the accuracy and fluency of the machining process.

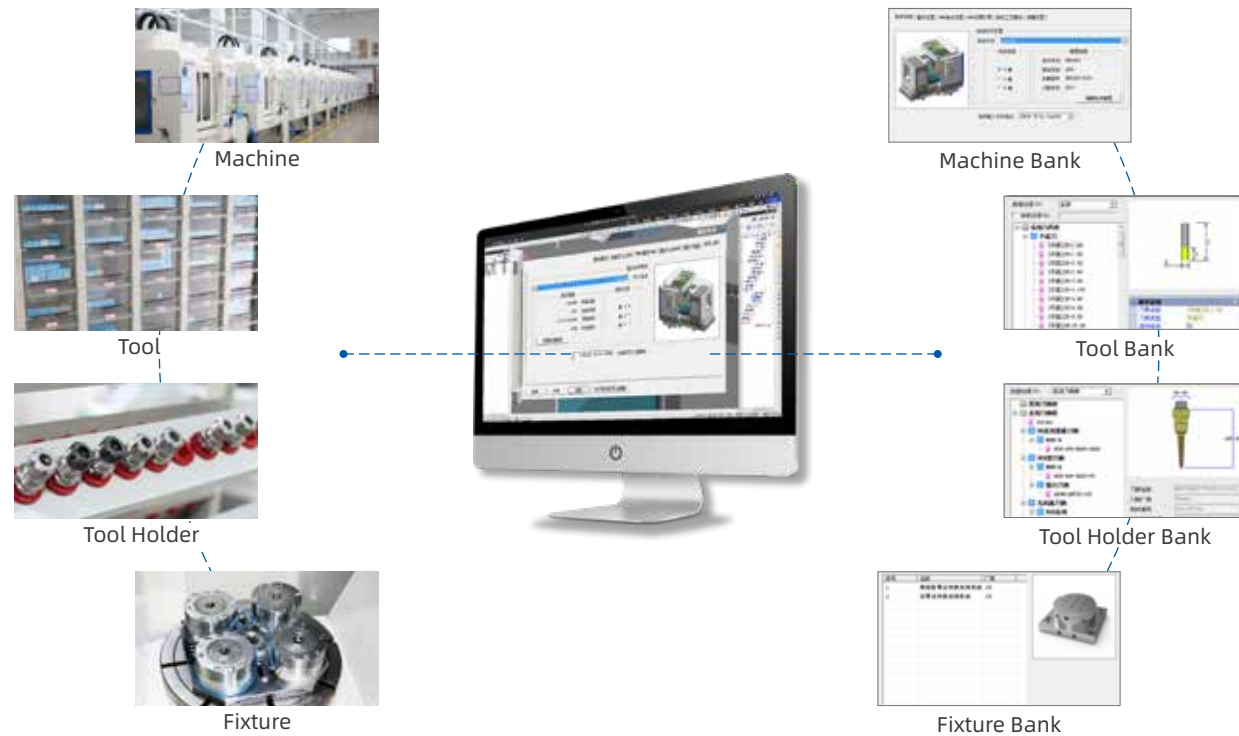

Ensuring the Safety of 5 Axis Machining

Five-axis milling is a complex machining process. During the machining there is the risk of collisions between tools, tool holders and the workpiece. Beijing JINGDIAO uses its SurfMill software to establish the connection between production materials, CAM programming and actual processing in a virtual environment. The user can build the same digital scene in the software, simulate the machining process, analyze and adjust the process, and eliminate the machining risk in the software programming stage.

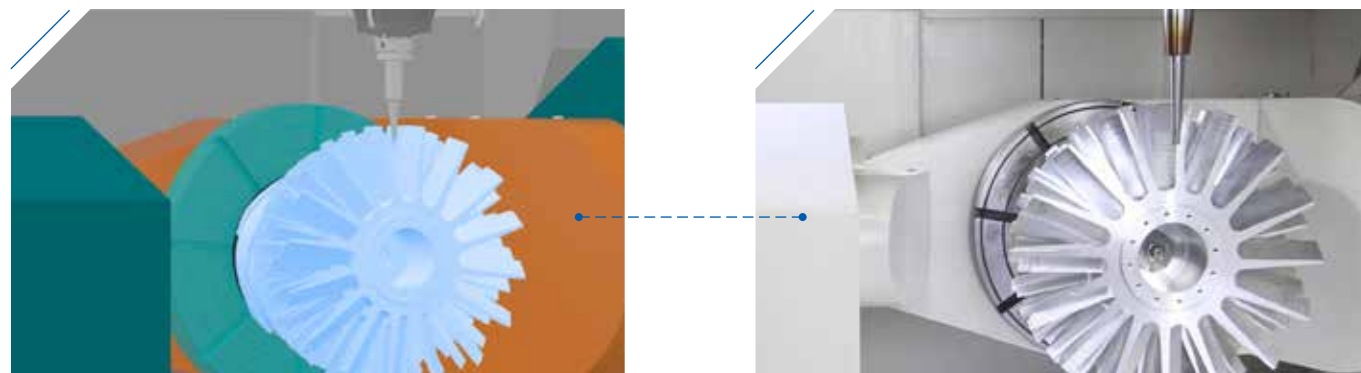

Application Scenarios of JINGDIAO DT Technology

Technical Points	Mirror the Actual Machining Environment to Ensure the Accuracy of Interference Risk Inspection	Informatization of Production Materials to Avoid Risks Caused by Wrong Selection of Materials	The Macro Program Fool-Proof to Avoid Risk Caused by Mis-Operation by Personnel								
1 Risk Type	 Z-Axis and Workpiece	 Tool Holder and Workpiece	 Spindle and Workpiece								
2 Cause of Risk	 Ignore Z-Axis	 No Informatization of Production Material	 Tool Clamping Length Error								
3 Solutions	 Complete Machine Model	 Informatization of Production Materials	 Logically Judge Whether the Tool Clamping Length is Within the Safe Value Range <table border="1"> <tr> <th colspan="2">Execution Condition</th> </tr> <tr> <td>Within Safe Range</td> <td>Exceed Safety Value</td> </tr> <tr> <td>Implementation Results</td> <td>Implementation Results</td> </tr> <tr> <td>✓</td> <td>⚠</td> </tr> </table> Tool Setup Foolproof	Execution Condition		Within Safe Range	Exceed Safety Value	Implementation Results	Implementation Results	✓	⚠
Execution Condition											
Within Safe Range	Exceed Safety Value										
Implementation Results	Implementation Results										
✓	⚠										

Easy Start

With this software, the program processing, measurement, preparation and logical judgment are combined into one program. The operator only needs to press the start button to begin the processing of the part which reduces machine setup time.

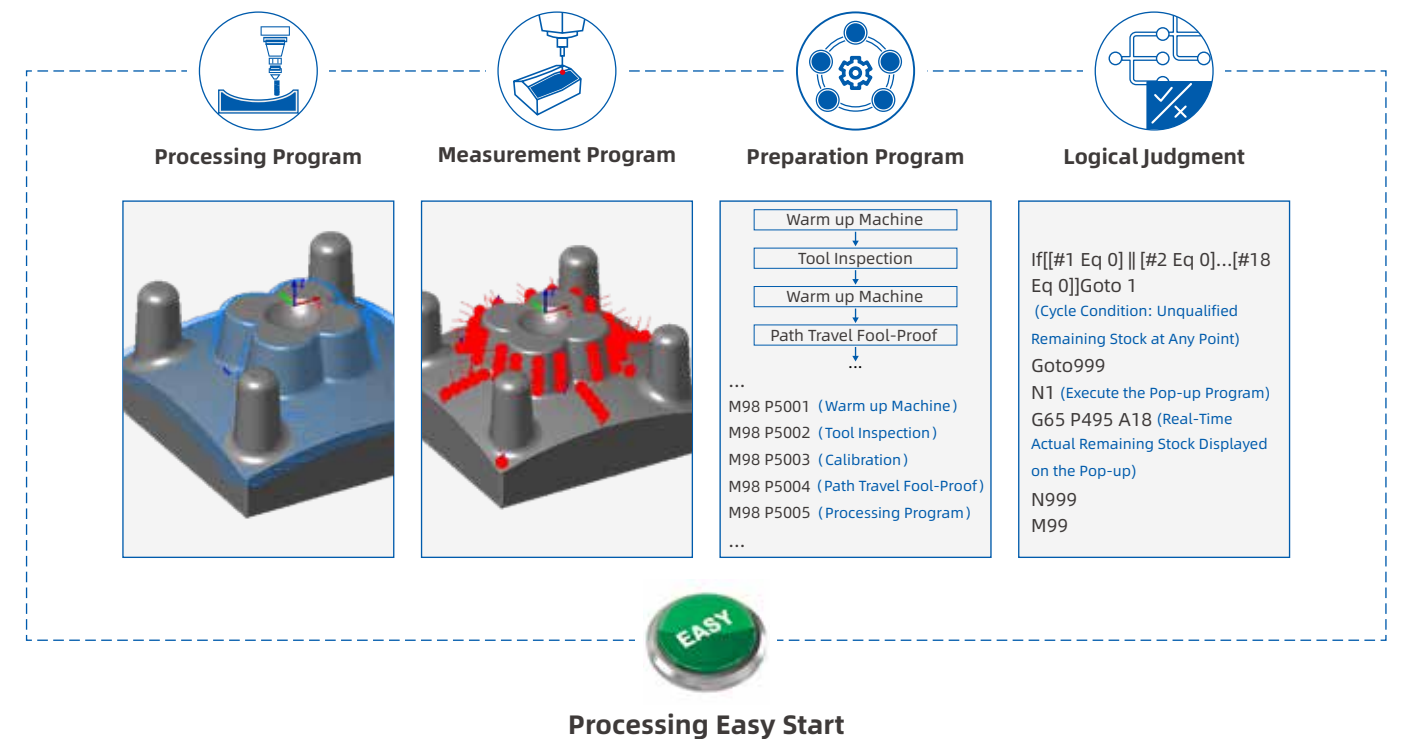

Technical Specification

Dimension Unit: mm (in)

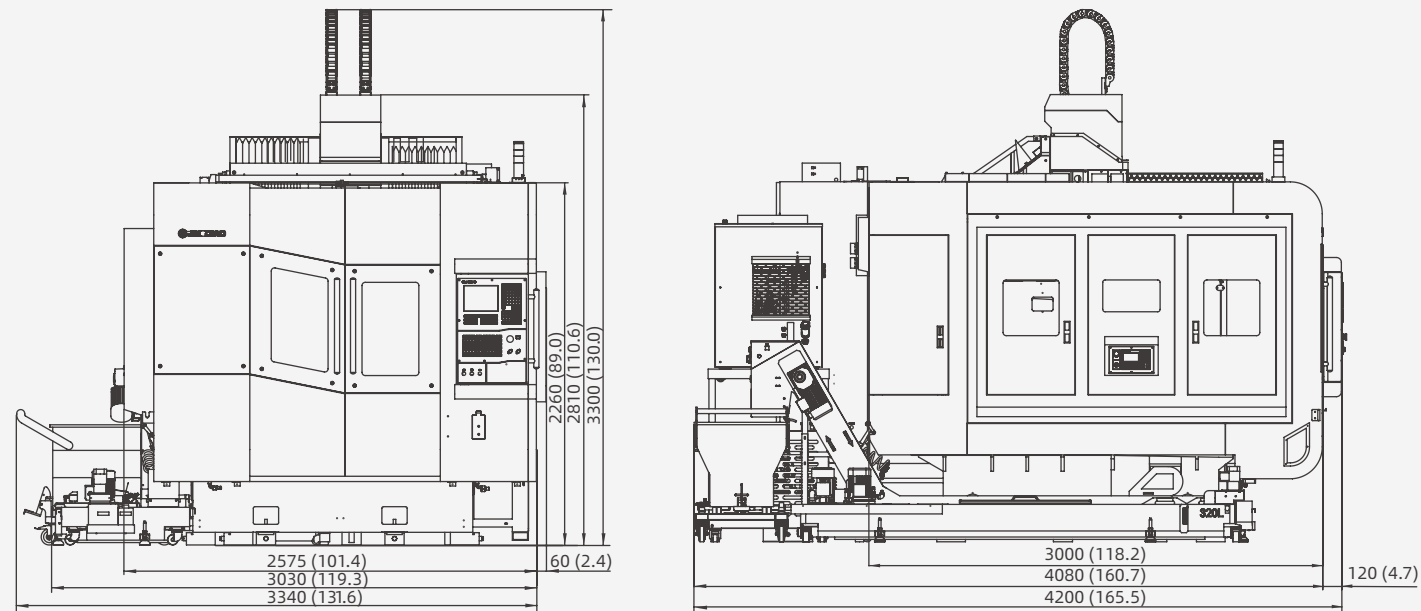

Layout Unit: mm (in)

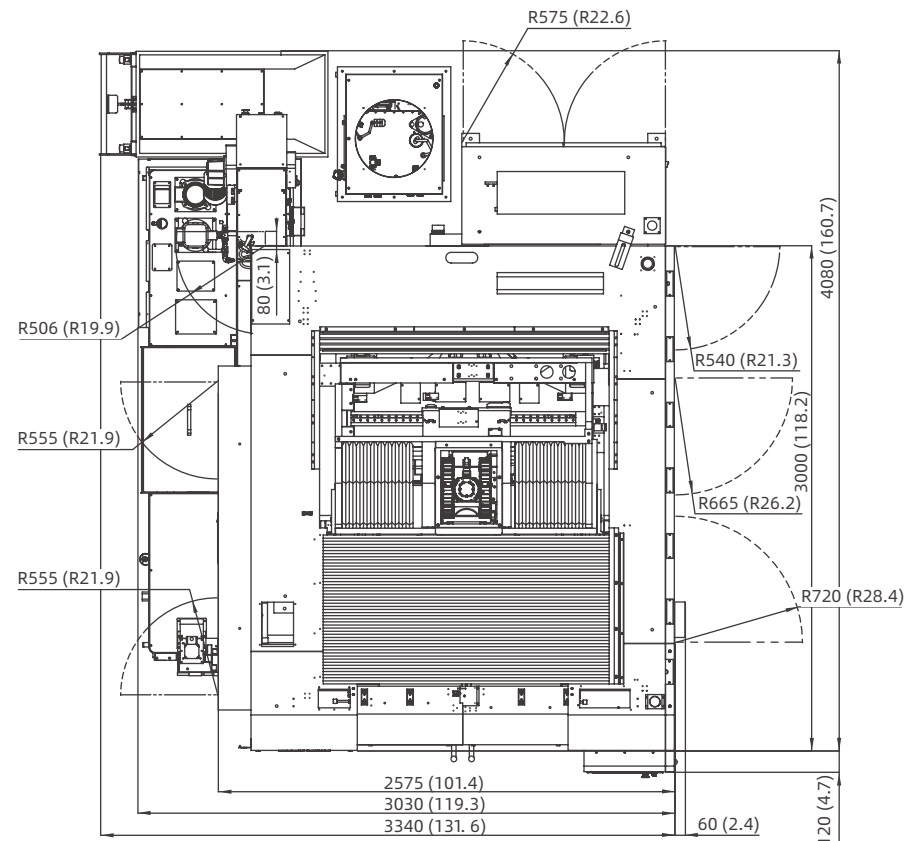

Items	Standard Value
Position Accuracy (X/Y/Z) mm/ (in)	0.003/0.003/0.003 (0.00012/ 0.00012/0.00012)
Position Accuracy (A/C) sec	8/8
Repeatability (X/Y/Z) mm/ (in)	0.002/0.002/0.002 (0.000079/ 0.000079/ 0.000079)
Repeatability (A/C) sec	5/5
Travel (X/Y/Z) (mm/in)	650×660×500 (25.60/25.98/19.69)
A/C Rotation Angle deg	-120~90/360
Table Diameter (mm/in)	φ630/φ24.8
Max. Load (kg/lb)	400 (881.85)
Max. Spindle Speed rpm	20,000 (HSK-A50)
	20,000 (HSK-A50)
	15,000 (HSK-A63)
	15,000 (HSK-A63)
Tool Magazine/Capacity	63 (Chain-Type Tool Magazine)
Rapid Speed (X/Y/Z) m/min (in/min)	15 (590.6)
Rapid Rotation Speed (A/C) rpm	60/60
Max. Cutting Feed Speed (X/Y/Z) m/min (in/min)	10 (393.7)
Max. Cutting Feed Speed (A/C) rpm	60/60
Drive System	AC Servo
Voltage	3-Phase, 480V/60Hz, or Customized
Air Pressure (Mpa/Psi)	0.35~0.4/50.76~58.02
Machine Weight (kg/lb)	12000 (26455.47)

Standard Features and Options

Items	Configuration
Control System	
JD50 CNC System	●
CAM Soft	
JDSoft SurfMill 9.0	●
Spindle	
JD150S-20-HA50/C (HSK-A50)	●
JD150SC-20-HA50/A (HSK-A50)	○
JD180S-15-HA63/B (HSK-A63)	○
JD180SC-15-HA63/B (HSK-A63)	○

Items	Configuration
Tool Magazine	
Chain Type Tool Magazine with Manipulator (63 Tools)	● (HSK-A50)
Chain Type Tool Magazine with Manipulator (51 Tools)	○ (HSK-A63)
Cooling System	
Coolant Device	●
Coolant Tank	○
Coolant Level Inspecting	●
Coolant Cooling System	○
Spindle Cooling	●
Rotary Table Cooling	●
Screw Cooling	●
Oil-Water Separator System	○
Oil-Mist Separator System	○
Micro Mist Lubrication	○
Chip Conveyor	
Chip Conveyor (Spiral Type)	●
Chip Conveyor (Scraper Type)	●
Air Blow System	●
Chip Collecting	●
Internal Spray Device	●
Measurement System	
Contact-Type Tool Set	●
Laser Tool Set	●
JINGDIAO On-Machine Measurement System	○
Standard Calibrating Ball	○
Others	
MPG (Manual Pulse Generator)	●
Bag Type Filtration System	○
Low Oil Pressure Inspection Device	●
Low Air Pressure Inspection Device	●
Ground Protector of Power Leakage	●
Machine Foot	●
Alarm	●
Lubricating Oil Inspection	●
Auto Power off Function	●
Internal Lighting Switch	●

+ Parameters above calibrates with reference to international standard ISO 230-2.

●: Standard ○: Optional

Stroke Diagram Unit: mm (in)

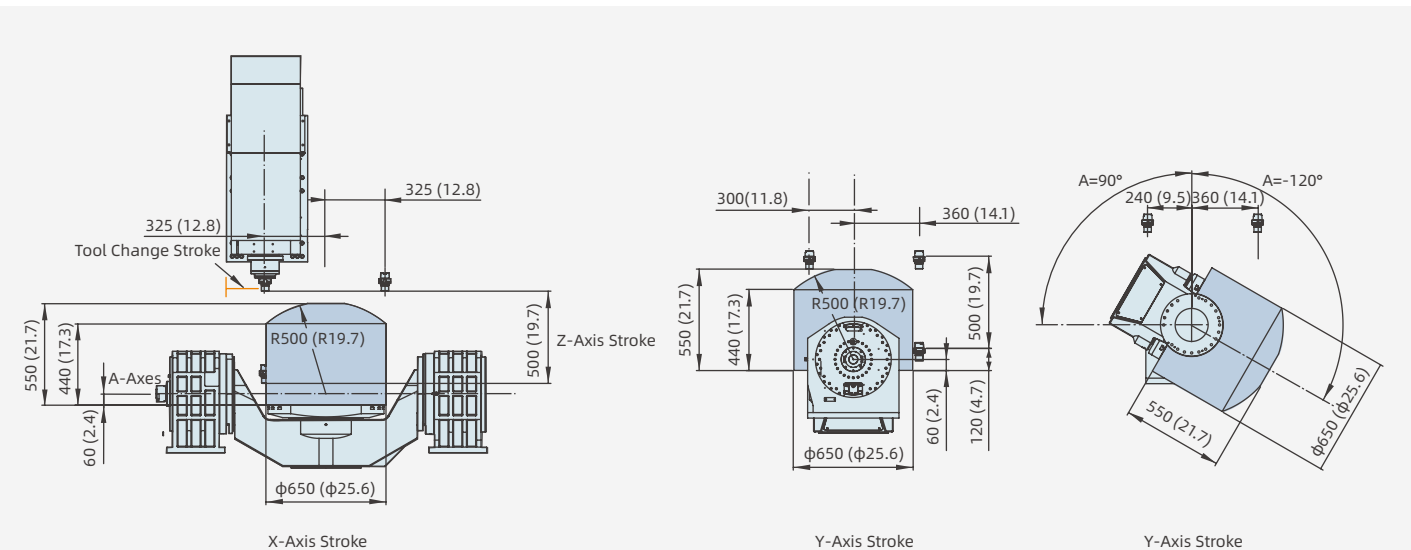

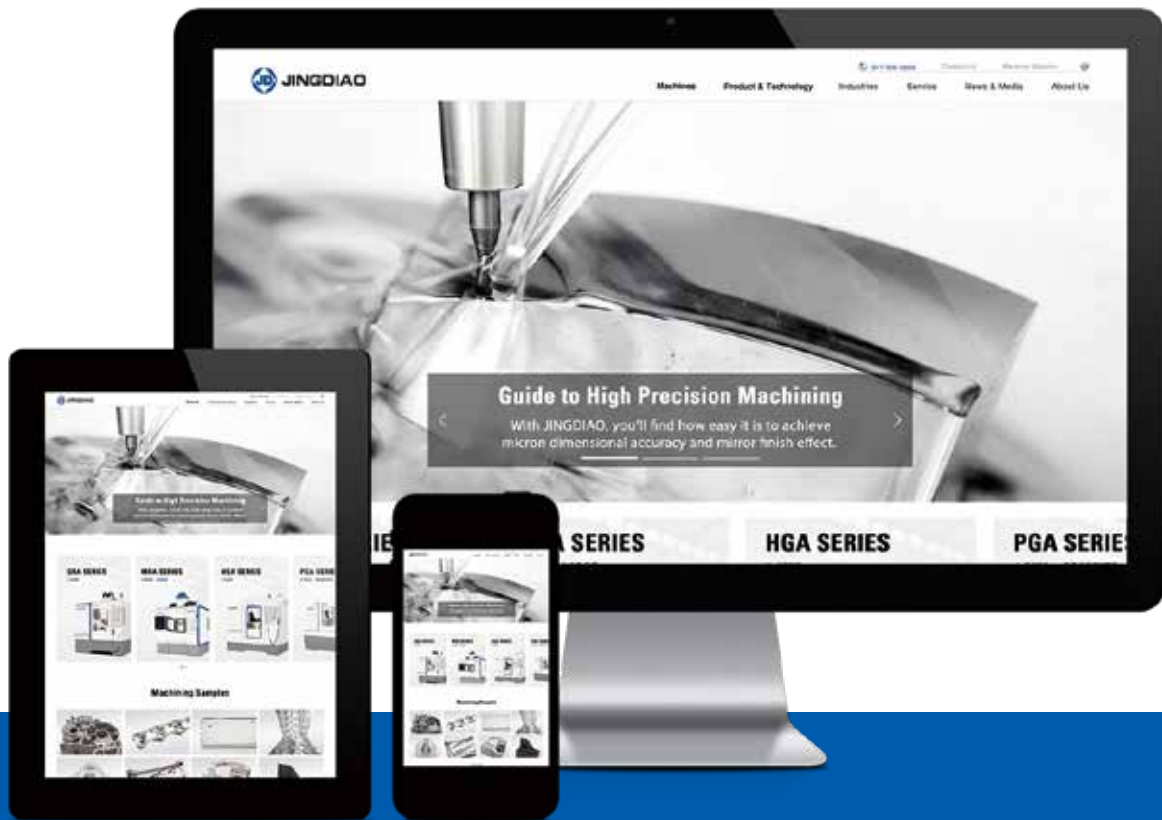

You can find more information at
us.jingdiao.com



Add: 1400 E. Business Center Drive, Ste. 103, Mount Prospect, IL 60056
Phone: (847) 906-8888
Fax: (847) 906-8800
Email: usa@jingdiao.com
Website: us.jingdiao.com

The pictures of the equipment are for your reference only. The configurations and parameters are subject to change without notice. The final interpretation of this brochure is owned by Beijing JINGDIAO Group Co., Ltd.